

DIFFERENTIAL PRESSURE TRANSMITTER/INDICATOR

DPT52I-F



Ex "d" Certified DP Port

Concealed Modular Wall
Flush Mount Design

Inbuilt DP Sensor

"DPT52I-F" is specially designed to measure differential pressures in FLP environment for Zone1, Zone2 Gas Gr. IIA & IIB. Instrument is user friendly and easy to operate. Software calibration with Magnetic keys eliminates instrument opening in restricted area.

Features

- Flame Proof Enclosure for Zone1, Zone2 Gas Gr. IIA, IIB
- 0.56", 3 Digit Seven Segment Red LED display
- Programmable Set points (HI/LO) for Visual and LED Annunciation
- Inbuilt DP Sensor
- Software Calibration & Ranging through magnetic key
- Password protected calibration & other programming modes

- Opto Isolated RS-485 MODBUS RTU Communication (optional)
- Analog output 4-20mA (optional)
- Digital output for hooter interface
- Clean Room compatible concealed modular wall flush mount enclosure (optional)

Applications

- DP measurement in Hazardous area

Network Architecture

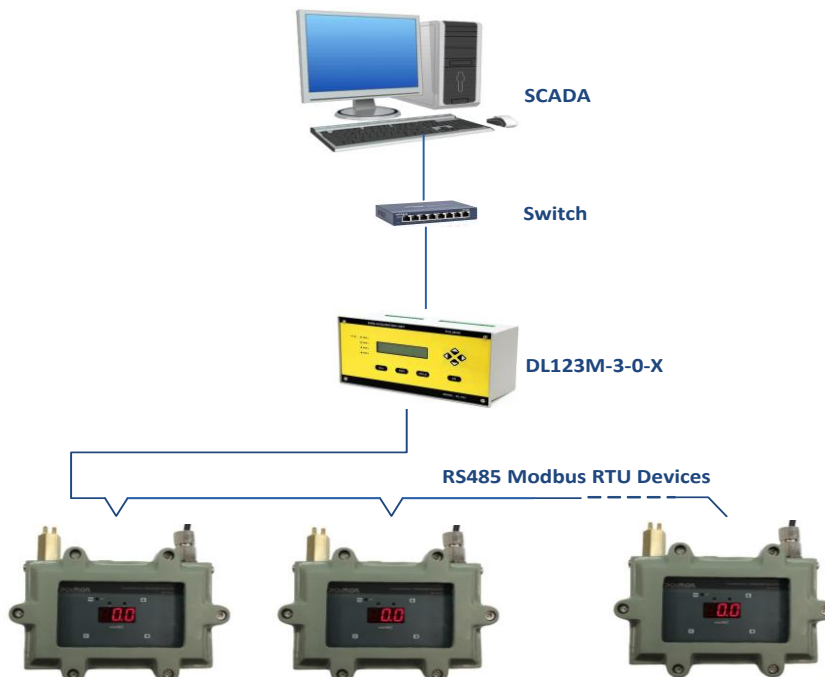

Specifications

Technical	
Model No	DPT521-F-X-X-X
DP Sensor	Inbuilt
Measurement range	±100mmWC / -199 to 980 Pa
Accuracy	±1.5% of reading ± 3counts for ±25.4 mmWC or -199 to 250 Pa and ±1.5% FSR for remaining
Resolution	mmWC : 0.1 Pa : 1
Communication	RS485 MODBUS RTU
Analog Output	4-20mA @ 500Ω load
Analog Output Accuracy	± 0.05 mA
Digital Output	1NO NC (Relay)
Response time	1 sec
Display	0.56" , 3 Digit Seven Segment Red LED display
Keypad	Magnetic Key
Calibration	Software Calibration upto 3 Point

Power Supply	
Input Supply	24V AC/DC±10%, 200mA
Physical	
Enclosure	Flame proof for Zone1, Zone2 Gas Gr.IIA, IIB
Material	Aluminium Alloy
Weight	2.2 Kg(Approx)
Dimensions	213x148x55mm
Mounting Options	Modular Wall Flush / On Wall
Modular wall Concealed Box Dimension	Cutout:228.5x214.5mm SS face plate:263x229x17mm Concealed Box:226x212x50 mm (Order Separately)
Cable Entries	5 No's ¾" ET
Glands / Dummies	Not Provided (Order Separately)
Environment	
Operating Temperature	10-60°C
Humidity	10-95%RH, non-Condensing
Media	Clean, Dry Air

Ordering Information for DPT521-F				
DPT521	X	X	X	X
<i>Model No.</i>	<i>Enclosure Type</i>	<i>Output Type</i>	<i>Display type</i>	<i>Future Use</i>
DPT521	F – FLP	1 – RS485	0 – No Display	X
		2 – 4-20mA	1 – With Display	

Note: Order separately

- DPT52FB-X-X-X (Modular wall Concealed Box)
- DPT52A-X (DP Port Assembly, 2Nos)

Modular Wall Mount Installation Drawing

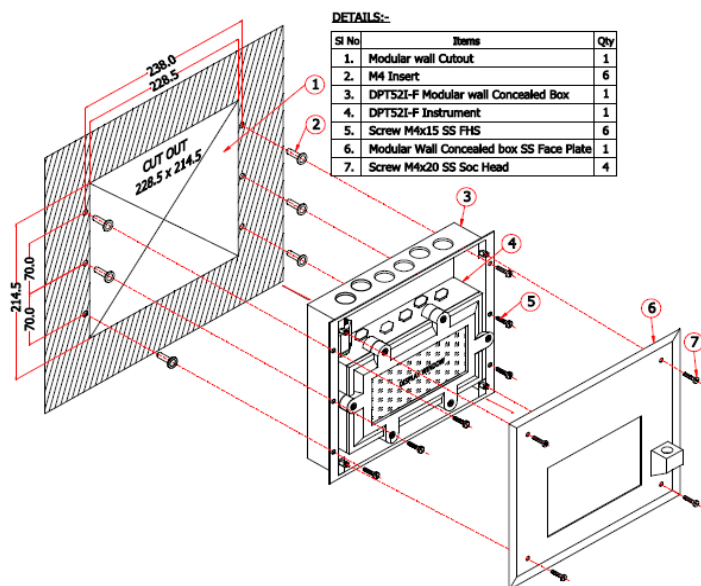

Instrument Dimensional Drawing

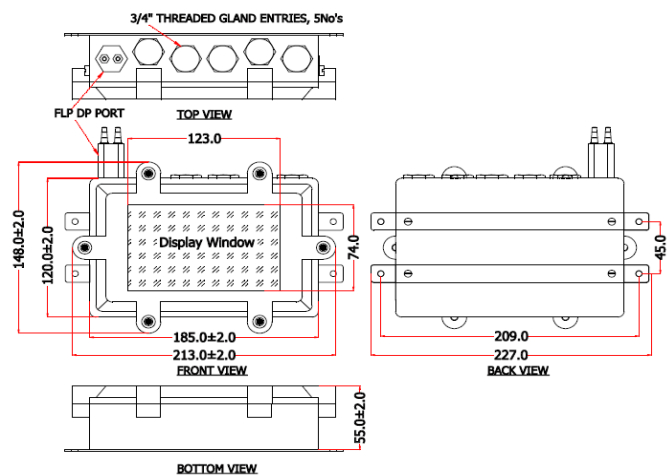

Head Office: POLMON INSTRUMENTS PVT.LTD
 (AN ISO 9001: 2015 Certified Company)
 "POLMON HOUSE" Nizampet Road, Kukatpally, Hyderabad-500085
 Ph No: 040-23053046, 23057308
 e-mail: polmon@polmon.com URL: www.polmon.com

All specifications are subject to change without notice.
 Doc. Ref. DPT521-F/121121/V1.2