

WATER LEVEL CONTROLLER

MODEL No: WLC -301

*** Controls your Water needs



Features:

- Conductivity principle
- Sensing Current: 100 MicroAmp, 15V AC Voltage (Human Safe)

Specifications:

Specifications	WLC301-F	WLC301-E
Control Type	Filling / Delivery Control	Emptying / Suction
Principle	Conductivity	
Levels	Minimum & Maximum	
Control Mode	Auto / Manual(ON, OFF) Selection Switch with LED Indication	
Relay Contacts	C, NO, NC rated 230VAC, 5Amp	
Sensing Current	100 MicroAmp, 15V AC Voltage (Human Safe)	
Enclosure	MS Enclosure with Brown Paint	
Power Supply	230V AC $\pm 10\%$, 50 Hz	
Mounting	Wall Mounting	

WATER LEVEL CONTROLLER SENSOR

MODEL No: WLC -301 S

Features:

- Material: SS304
- Construction Style: Heavy duty,
3 No.s SS304 wire's suspended in liquid
- Mounting: Vertical
- Terminal Housing: Weather Proof

Ordering Information: -

Refer model numbers for ordering code.

Applications:-

Used for filling or emptying water tanks.

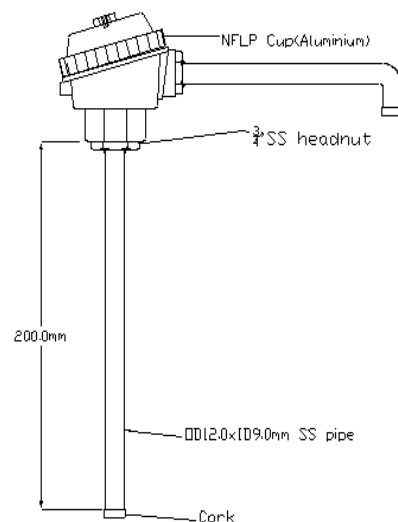

For Further Information Contact:

POLMON INSTRUMENTS PVT.LTD

(AN ISO 9001: 2000 Certified Company)

“POLMON HOUSE” Nizampet Road, Kukatpally, Hyderabad – 500 072

Ph No: 040-23053046, 23057308, 23055970, 23057642

Customer Care: 040-23892920 Fax: 040 – 23055425

e-mail: polmon@polmon.com URL: www.polmon.com